



CITY MULTI ^{<ORIGINAL>}

**AIR CONDITIONING SYSTEMS
CONNECTION KIT
PAC-LV11M-J**



INSTALLATION MANUAL

For safe and correct use, please read this installation manual thoroughly before installing the indoor unit.

GB

Contents

1. Safety precautions	2	2.4. Dip switch setting	18
1.1. Before installation and electric work	2	3. Specifications	19
1.2. Precautions for devices that use R410A refrigerant	2	4. Outlines and dimensions	20
1.3. Before getting installed	3	5. Wiring diagram	21
1.4. Before getting installed (moved) - electrical work	3	6. Refrigerant system diagram	22
1.5. Before starting the test run	3	7. Troubleshooting	23
2. Overview of units	4	7.1. Test run	23
2.1. System outline	4	7.2. Check methods	24
2.2. Unit construction	4	7.3. Dip switch setting (Factory setting)	27
2.3. Installation	5		

- Some indoor units require dip switch setting changes or additional refrigerant charge. Refer to the “LEV kit connectable unit model list” (WT08359) for details.
- Obtain the “LEV kit connectable unit model list” (WT08359) using either the following methods:
 - Download from Next2.
 - Consult your dealer.

1. Safety precautions

1.1. Before installation and electric work

- ▶ Before installing the unit, make sure you read all the “Safety precautions”.
- ▶ The “Safety precautions” provide very important points regarding safety. Make sure you follow them.

Symbols used in the text





Warning:

Describes precautions that should be observed to prevent danger of injury or death to the user.

Caution:

Describes precautions that should be observed to prevent damage to the unit.

Symbols used in the illustrations

-  : Indicates an action that must be avoided.
-  : Indicates that important instructions must be followed.
-  : Indicates a part which must be grounded.
-  : Indicates that caution should be taken with rotating parts. (This symbol is displayed on the main unit label.) <Color: yellow>
-  : Beware of electric shock (This symbol is displayed on the main unit label.) <Color: yellow>

Warning:

Carefully read the labels affixed to the main unit.

Warning:

- **Ask the dealer or an authorized technician to install the connection kit.**
 - Improper installation by the user may result in water leakage, electric shock, or fire.
- **Install the unit at a place that can withstand its weight.**
 - Inadequate strength may cause the unit to fall down, resulting in injuries.
- **Use the specified cables for wiring. Make the connections securely so that the outside force of the cable is not applied to the terminals.**
 - Inadequate connection and fastening may generate heat and cause a fire.
- **Prepare for typhoons and other strong winds and earthquakes and install the unit at the specified place.**
 - Improper installation may cause the unit to topple and result in injury.
- **Always use an air cleaner, humidifier, electric heater, and other accessories specified by Mitsubishi Electric.**
 - Ask an authorized technician to install the accessories. Improper installation by the user may result in water leakage, electric shock, or fire.
- **Never repair the unit. If the unit must be repaired, consult the dealer.**
 - If the unit is repaired improperly, water leakage, electric shock, or fire may result.
- **When handling this product, always wear protective equipment.**
EG: Gloves, full arm protection namely boiler suit, and safety glasses.
 - Improper handling may result in injury.
- **If refrigerant gas leaks during installation work, ventilate the room.**
 - If the refrigerant gas comes into contact with a flame, poisonous gases will be released.
- **Install the unit according to this Installation Manual.**
 - If the unit is installed improperly, water leakage, electric shock, or fire may result.

- **Have all electric work done by a licensed electrician according to “Electric Facility Engineering Standard” and “Interior Wire Regulations” and the instructions given in this manual and always use a special circuit.**
 - If the power source capacity is inadequate or electric work is performed improperly, electric shock and fire may result.
- **Keep the electric parts away from water (washing water etc.).**
 - It might result in electric shock, catching fire or smoke.
- **When installing and moving the unit to another site, do not charge the it with a refrigerant different from the refrigerant specified on the unit.**
 - If a different refrigerant or air is mixed with the original refrigerant, the refrigerant cycle may malfunction and the unit may be damaged.
- **If the unit is installed in a small room, measures must be taken to prevent the refrigerant concentration from exceeding the safety limit even if the refrigerant should leak.**
 - Consult the dealer regarding the appropriate measures to prevent the safety limit from being exceeded. Should the refrigerant leak and cause the safety limit to be exceeded, hazards due to lack of oxygen in the room could result.
- **When moving and reinstalling the unit, consult the dealer or an authorized technician.**
 - If the air conditioner is installed improperly, water leakage, electric shock, or fire may result.
- **After completing installation work, make sure that refrigerant gas is not leaking.**
 - If the refrigerant gas leaks and is exposed to a fan heater, stove, oven, or other heat source, it may generate noxious gases.
- **Do not reconstruct or change the settings of the protection devices.**
 - If the pressure switch, thermal switch, or other protection device is shorted and operated forcibly, or parts other than those specified by Mitsubishi Electric are used, fire or explosion may result.
- **To dispose of this product, consult your dealer.**
- **Do not use a leak detection additive.**

1.2. Precautions for devices that use R410A refrigerant

Caution:

- **Do not use the existing refrigerant piping.**
 - The old refrigerant and refrigerator oil in the existing piping contains a large amount of chlorine which may cause the refrigerator oil of the new unit to deteriorate.
- **Use refrigerant piping made of C1220 (Cu-DHP) phosphorus deoxidized copper as specified in the JIS H3300 “Copper and copper alloy seamless pipes and tubes”. In addition, be sure that the inner and outer surfaces of the pipes are clean and free of hazardous sulphur, oxides, dust/dirt, shaving particles, oils, moisture, or any other contaminant.**
 - Contaminants on the inside of the refrigerant piping may cause the refrigerant residual oil to deteriorate.
- **Store the piping to be used during installation indoors and keep both ends of the piping sealed until just before brazing. (Store elbows and other joints in a plastic bag.)**
 - If dust, dirt, or water enters the refrigerant cycle, deterioration of the oil and compressor trouble may result.
- **Use liquid refrigerant to fill the system.**
 - If gas refrigerant is used to seal the system, the composition of the refrigerant in the cylinder will change and performance may drop.
- **Do not use a refrigerant other than R410A.**
 - If another refrigerant (R22, etc.) is used, the chlorine in the refrigerant may cause the refrigerator oil to deteriorate.

- **Use a vacuum pump with a reverse flow check valve.**
 - The vacuum pump oil may flow back into the refrigerant cycle and cause the refrigerator oil to deteriorate.
- **Do not use the following tools that are used with conventional refrigerants.**

(Gauge manifold, charge hose, gas leak detector, reverse flow check valve, refrigerant charge base, vacuum gauge, refrigerant recovery equipment)

 - If the conventional refrigerant and refrigerator oil are mixed in the R410A, the refrigerant may deteriorate.
 - If water is mixed in the R410A, the refrigerator oil may deteriorate.
 - Since R410A does not contain any chlorine, gas leak detectors for conventional refrigerants will not react to it.
- **Do not use a charging cylinder.**
 - Using a charging cylinder may cause the refrigerant to deteriorate.
- **Be especially careful when managing the tools.**
 - If dust, dirt, or water gets in the refrigerant cycle, the refrigerant may deteriorate.

1.3. Before getting installed

Caution:

- **Do not install the unit where combustible gas may leak.**
 - If the gas leaks and accumulates around the unit, an explosion may result.
- **Do not use the connection kit where food, pets, plants, precision instruments, or artwork are kept.**
 - The quality of the food, etc. may deteriorate.
- **Do not use the unit in special environments.**
 - Oil, steam, sulfuric smoke, etc. can significantly reduce the performance of the unit or damage its parts.
- **When installing the unit in a hospital, communication station, or similar place, provide sufficient protection against noise.**
 - The inverter equipment, private power generator, high-frequency medical equipment, or radio communication equipment may cause the air conditioner to operate erroneously, or fail to operate. On the other hand, the unit may affect such equipment by creating noise that disturbs medical treatment or image broadcasting.
- **Do not install the unit on a structure that may cause leakage.**
 - When the room humidity exceeds 80% or when the drain pipe is clogged, condensation may drip from the indoor unit. Perform collective drainage work together with the outdoor unit, as required.
- **The unit should be installed the ceiling over than 2.5 m from floor.**

1.4. Before getting installed (moved) - electrical work

Caution:

- **Ground the unit.**
 - Do not connect the ground wire to gas or water pipes, lightning rods, or telephone ground lines. Improper grounding may result in electric shock.
- **Install the power cable so that tension is not applied to the cable.**
 - Tension may cause the cable to break and generate heat and cause a fire.
- **Install a leak circuit breaker, as required.**
 - If a leak circuit breaker is not installed, electric shock may result.
- **Use power line cables of sufficient current carrying capacity and rating.**
 - Cables that are too small may leak, generate heat, and cause a fire.
- **Use only a circuit breaker and fuse of the specified capacity.**
 - A fuse or circuit breaker of a larger capacity or a steel or copper wire may result in a general unit failure or fire.
- **Do not wash the unit.**
 - Washing them may cause an electric shock.
- **Be careful that the installation base is not damaged by long use.**
 - If the damage is left uncorrected, the unit may fall and cause personal injury or property damage.
- **Install the drain piping according to this Installation Manual to ensure proper drainage. Wrap thermal insulation around the pipes to prevent condensation.**
 - Improper drain piping may cause water leakage and damage to furniture and other possessions.
- **Be very careful about product transportation.**
 - Some products use PP bands for packaging. Do not use any PP bands for a means of transportation. It is dangerous.
- **Safely dispose of the packing materials.**
 - Packing materials, such as nails and other metal or wooden parts, may cause stabs or other injuries.
 - Tear apart and throw away plastic packaging bags so that children will not play with them. If children play with a plastic bag which was not torn apart, they face the risk of suffocation.

1.5. Before starting the test run

Caution:

- **Turn on the power at least 12 hours before starting operation.**
 - Starting operation immediately after turning on the main power switch can result in severe damage to internal parts. Keep the power switch turned on during the operational season.
- **Do not touch the switches with wet fingers.**
 - Touching a switch with wet fingers can cause electric shock.
- **Do not touch the refrigerant pipes during and immediately after operation.**
 - During and immediately after operation, the refrigerant pipes are may be hot and may be cold, depending on the condition of the refrigerant flowing through the refrigerant piping, compressor, and other refrigerant cycle parts. Your hands may suffer burns or frostbite if you touch the refrigerant pipes.
- **Do not operate the unit with the panels and guards removed.**
 - Rotating, hot, or high-voltage parts can cause injuries.
- **Do not turn off the power immediately after stopping operation.**
 - Always wait at least five minutes before turning off the power. Otherwise, water leakage and trouble may occur.
- **If the supply cord is damaged, it must be replaced by the manufacturer, its service agent or similarly qualified persons in order to avoid a hazard.**

• **This appliance is not intended for use by persons (including children) with reduced physical, sensory or mental capabilities, or lack of experience and knowledge, unless they have been given supervision or instruction concerning use of the appliance by a person responsible for their safety.**

• **Children should be supervised to ensure that they do not play with the appliance.**

- **This appliance is intended to be used by expert or trained users in shops, in light industry and on farms, or for commercial use by lay persons.**

2. Overview of units

2.1. System outline

2.1.1. System example

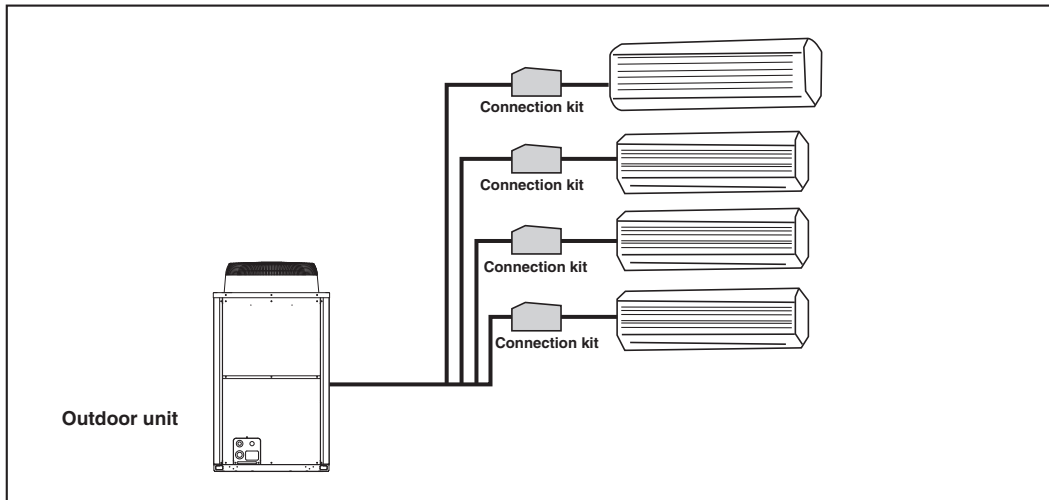

2.2. Unit construction

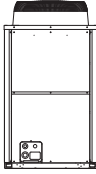
Outdoor unit		
Indoor unit that can be connected	Capacity	Refer to manuals of the outdoor unit.
	Number of units	
	Total system wide capacity	

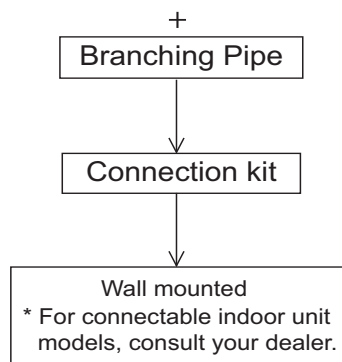

2.3. Installation

2.3.1. Installing the connection kit

Parts to procure locally

- Suspension bolts or anchor bolts : W3/8 (M10)
- Nut : W3/8 (M10)
- Washer : W3/8 (M10)

Installing the unit in a ceiling

(1) Install the suspension bolts.

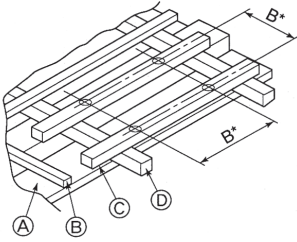
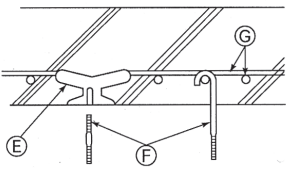
	<p>Wooden structures</p> <ul style="list-style-type: none"> • Use tie beams (single storied houses) or second floor beams (two story houses) as reinforcing members. • Wooden beams for suspending air conditioners must be sturdy and their sides must be at least 6 cm long if the beams are separated by not more than 90 cm. The size of the suspension bolts should be M10 (W3/8). (The bolts are not supplied with the unit.) <p>Ⓐ Ceiling Ⓑ Rafter Ⓒ Beam Ⓓ Roof beam B* Suspension bolt pitch</p>
	<p>Ferro-concrete structures</p> <p>Secure the suspension bolts using the method shown, or use steel or wooden hangers, etc. to install the suspension bolts.</p> <p>Ⓔ Use inserts rated at 100-150 kg each (procure locally) Ⓕ Suspension bolts M10 (W3/8) (procure locally) Ⓖ Steel reinforcing rod</p>

(2) Install the connection kit.

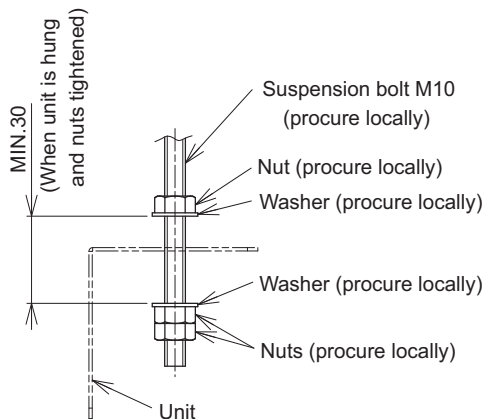

(Unit: mm)

Installing the unit on a wall

(1) Install the anchor nuts.

(2) Install the connection kit.

Do not install the refrigerant pipes on top of the unit when installing the unit on a wall, otherwise condensation can enter the electrical devices, which can cause an electric shock or a fire.

Connect the Connection Kit to the liquid pipe and install it inside the ceiling or on a wall (Do not install in an outdoor location. It may cause a breakdown). Make sure to install the access door on the ceiling.

Installation location

- The installation patterns below are available. Select the installation pattern according to the preferred installation method. The distance between indoor unit and Connection Kit is within 15 m. (Pipe:15 m, Cable:2.5 m)
- Install the connection kit at a height of 2.5 m or above from the floor, where it is not easily accessible for the users.

Installation pattern A (Using suspension bolt ; recommended pattern)

Set the Connection Kit mounting plate as shown below.

The mounting plate can also be fixed to suspension bolts before it is fixed to the Connection Kit.

(Unit: mm)

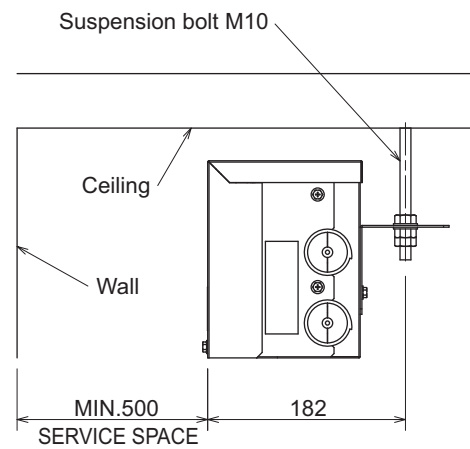
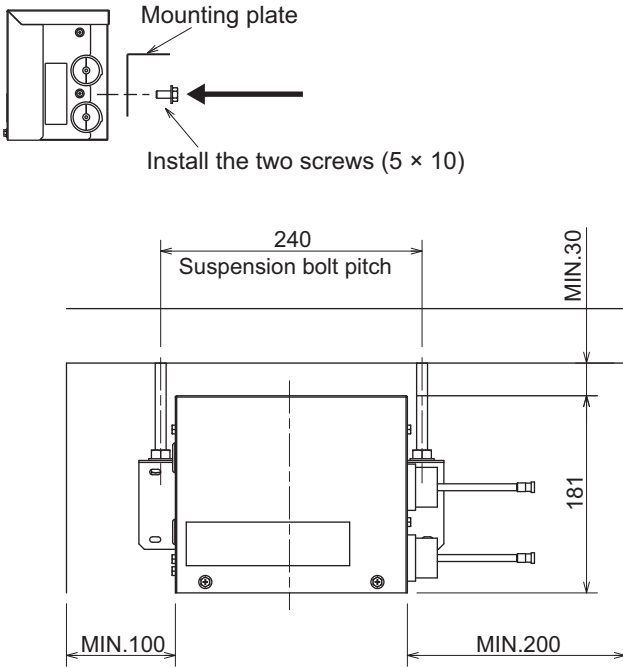

Installation pattern B (Installing the unit on a wall.)

Set the Connection Kit mounting plate as shown below.

(Unit: mm)

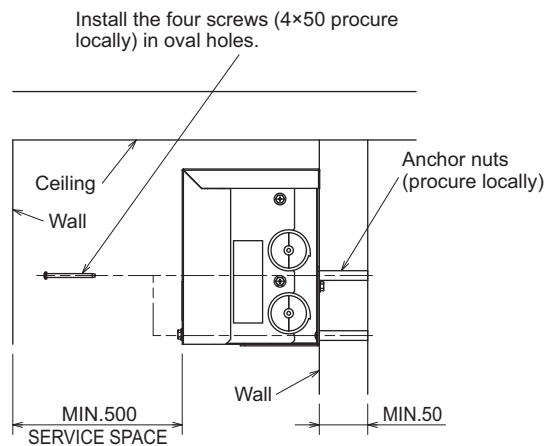
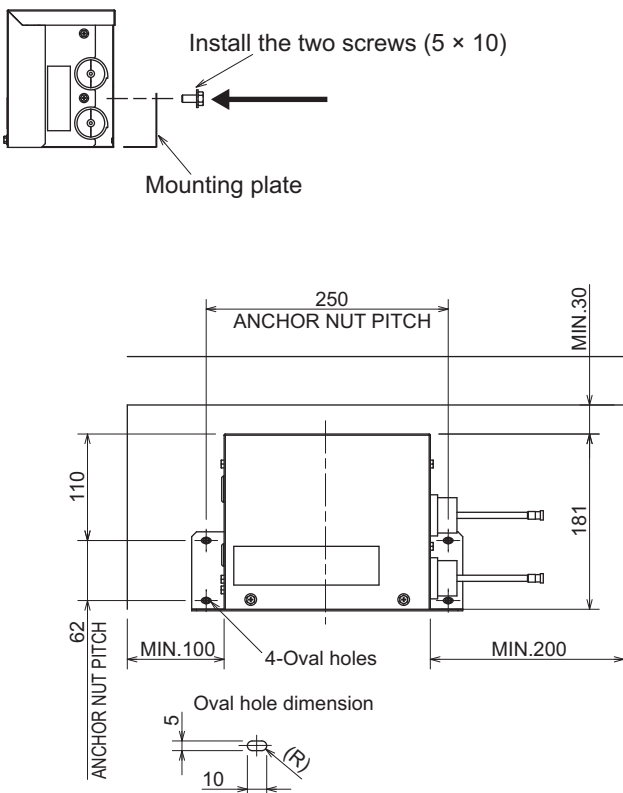

Installation pattern C (Installing the unit on a wall.)

Set the Connection Kit mounting plate as shown below.

(Unit: mm)

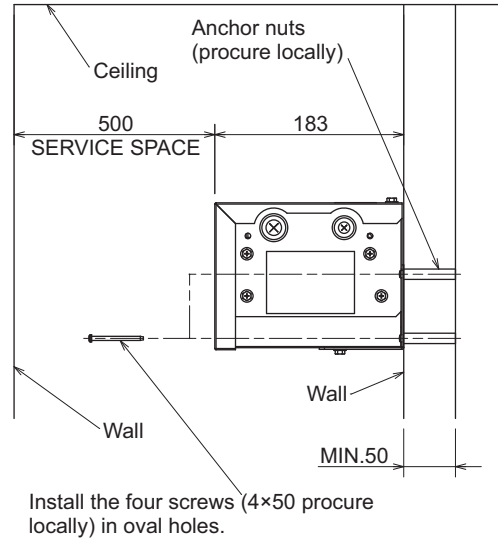
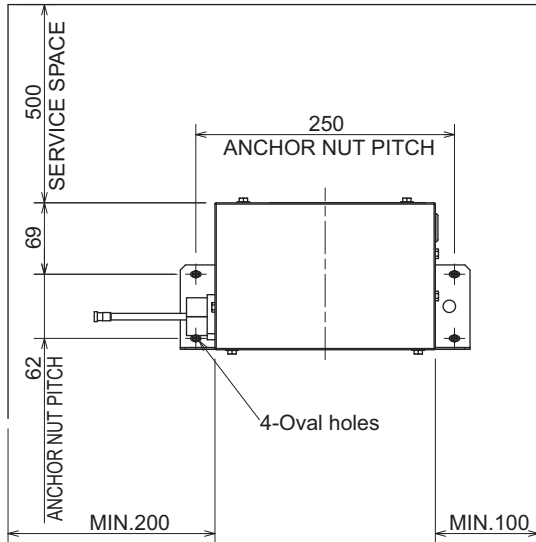
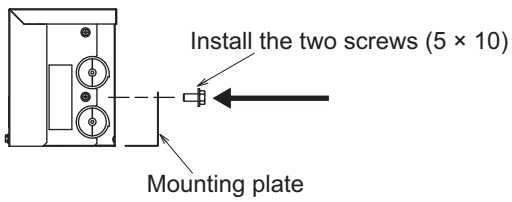

Installation pattern D (Installing the unit on a wall.)

Set the Connection Kit mounting plate as shown below.

(Unit: mm)

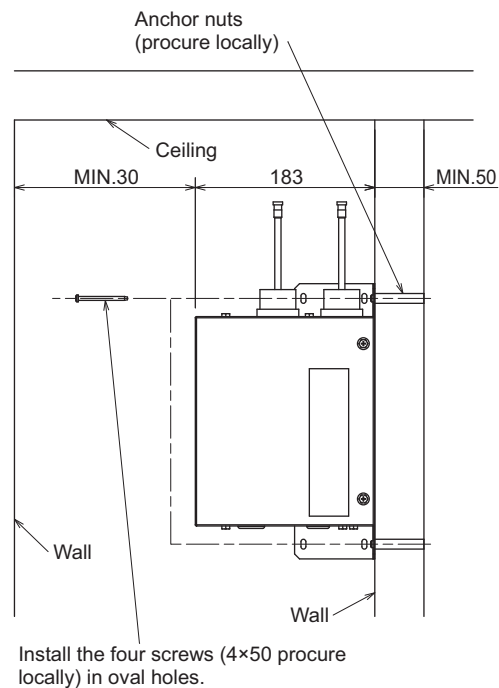
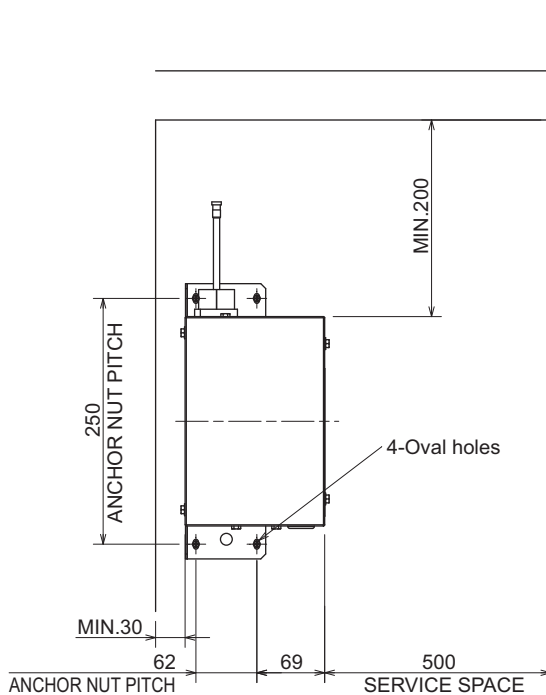
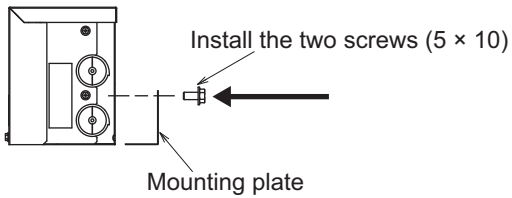

2.3.2. Installing the refrigerant piping

Check the Connection Kit accessories and parts

- ① Pipe cover × 2
- ② Thermistor holder - $\varnothing 9.52 \times 1$
- ③ Thermistor holder - $\varnothing 12.7 \times 1$

Connect Connection Kit to the liquid pipe.

When brazing the refrigerant pipes, be sure to braze, after covering a wet cloth to the insulation pipes of the units in order to prevent it from burning and shrinking by heat.

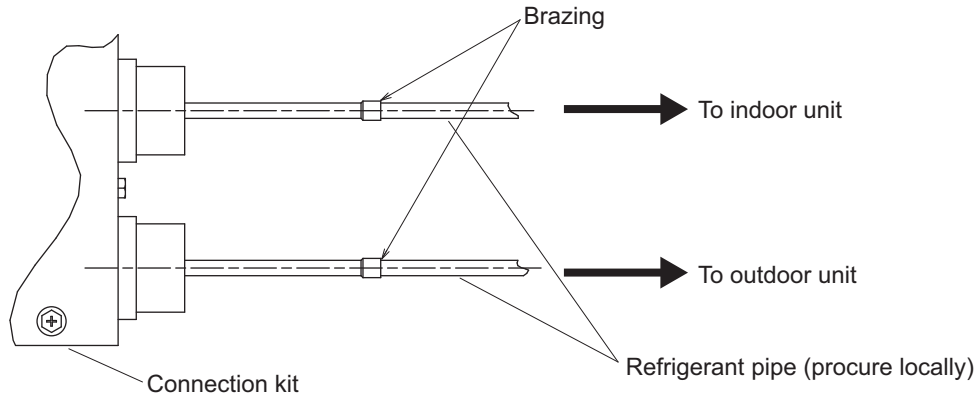

Press the pipe cover ① on the liquid piping against the Connection Kit and wrap it to hold it in place. Fasten the supplied bands 20 mm from each of the pipe covers ①.

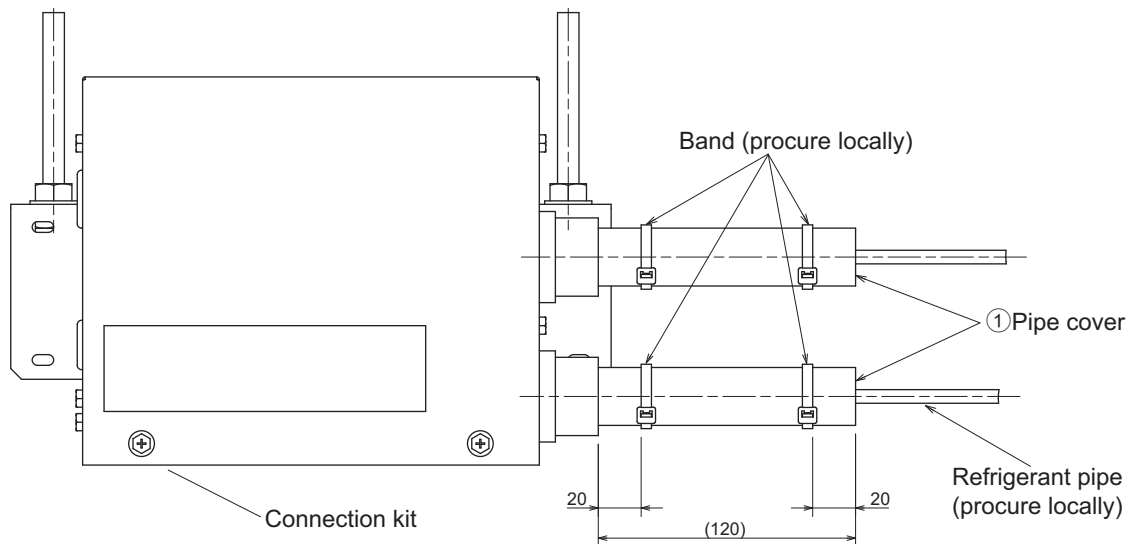

Wrap the pipe cover ① with tape.

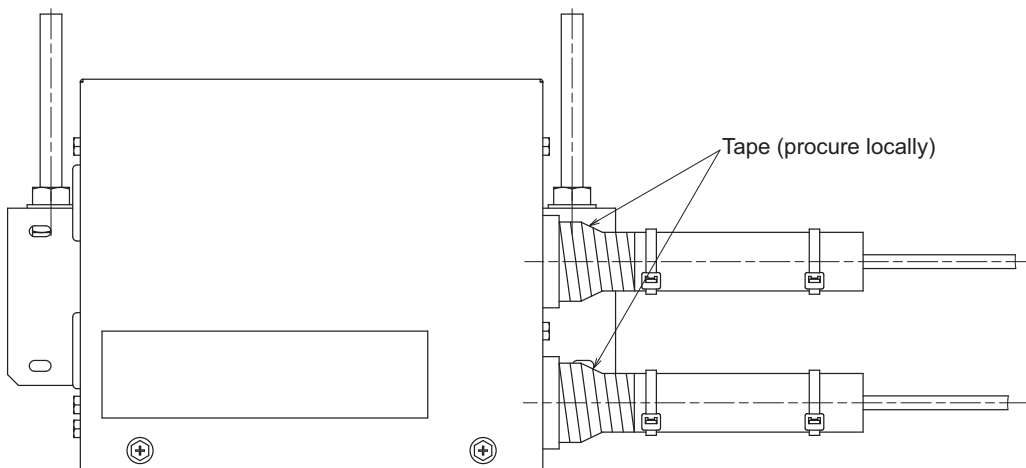

2.3.3. Installing the thermistors

Be sure to install the thermistors (gas) supplied with the unit as shown in the illustration.

- If the thermistors are not installed, the unit will not operate. If the thermistors are installed incorrectly, the unit will not operate properly.

Take precaution so that condensation does contact the thermistor leads or enters the electrical devices.

Before installing thermal insulation to the frame connecting points of the indoor unit, be sure to install the thermistors according to the procedures given on this page.

* Refer to section 5. "Wiring diagram" for the location of CN44.

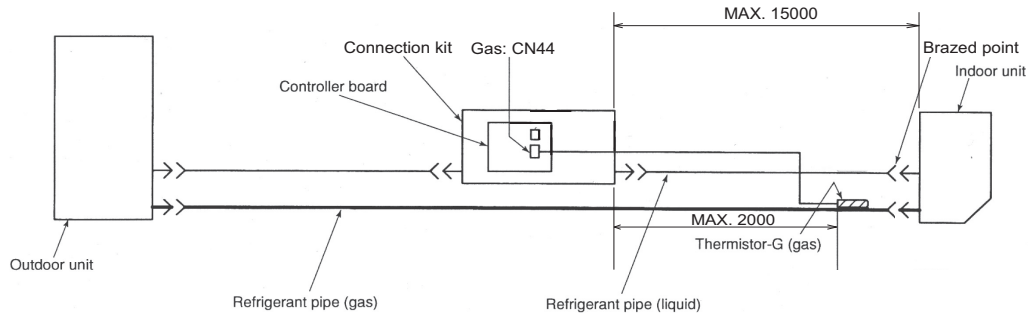

Thermistor installation order

(1) Securely fasten the thermistor (gas) supplied with the unit using the thermistor holders (②, ③) at the fastening points of indoor unit refrigerant pipes.

- Set thermistor-G (gas) in thermistor holders ② or ③, and then fasten the refrigerant pipes.

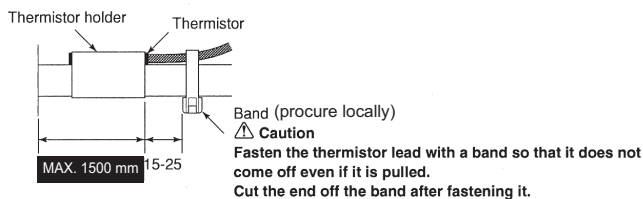
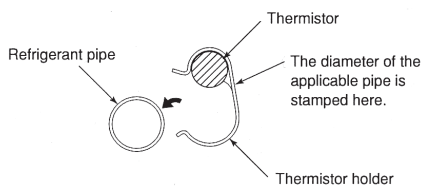

Select thermistor holders that match the size of the refrigerant piping.

Indoor unit capacity	pipe size (mm)	
	Liquid	Gas
15-40	ø6.35	ø9.52
50	ø6.35	ø12.7

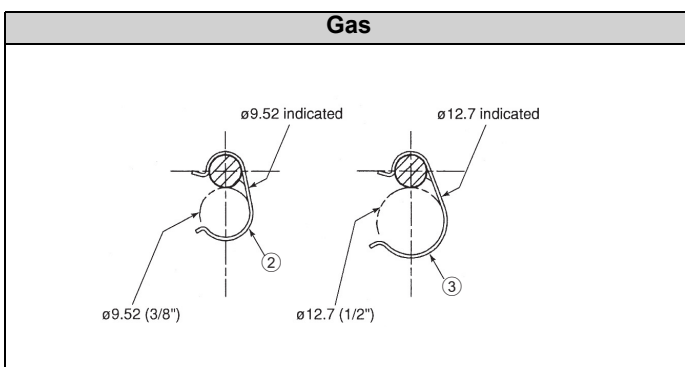

⚠ Caution:

- To prevent condensation from dripping on the thermistor fasteners, wrap them with sufficient thermal insulation.
- Install the thermistor so that the piping is on top (as shown in above illustration).
- Take out the thermistor lead from above the piping.
- Install the thermistor indoors.

- Route the following lead, line, and cable pairs so that they do not come into contact with each other.
 - Thermistor lead and indoor unit-connection kit transmission line
 - Thermistor lead and power supply cable
 - Transmission line and power supply cable

(2) Insulate the thermistor with the supplied thermal insulation (procure locally).

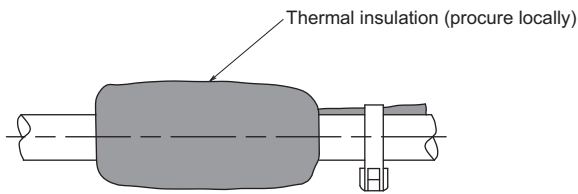

(3) Cut a 100 mm slit on the top portion of the extension piping pipe cover, and then cover the thermistors with the pipe cover.

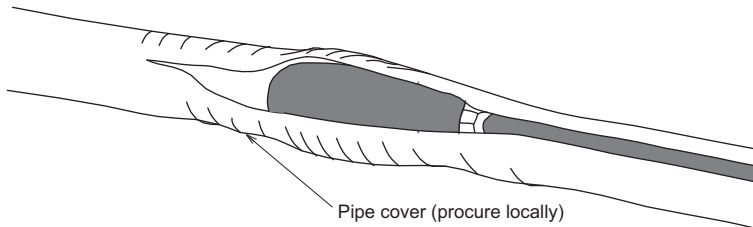

(4) Wrap the thermal insulation covering the thermistor with tape.

⚠ Caution:
Be sure to take out the thermistor lead from above.

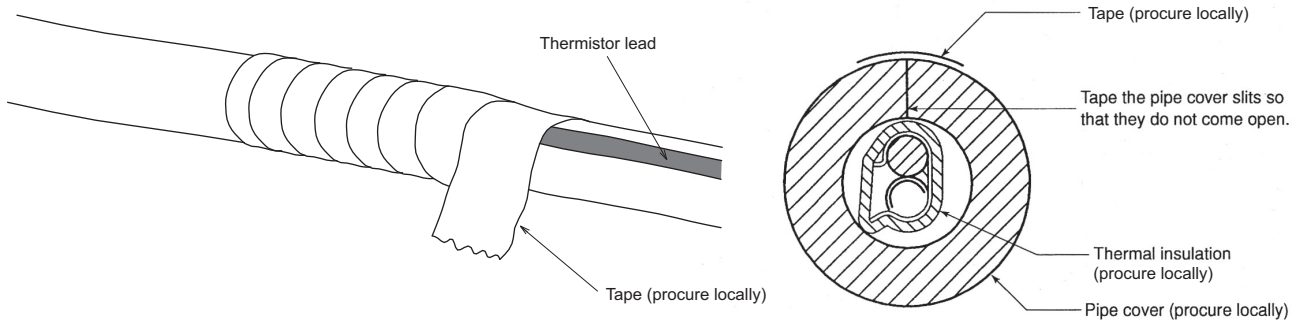

(5) Cover the thermistor with the thermal insulation.

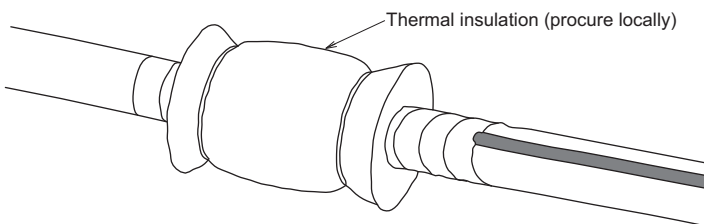

Bundle up the excess thermistor lead.

- ⚠ Caution:**
- Do not make the thermistor lead taut.
 - Do not add extensions to the thermistor lead.
 - Do not cut the excess thermistor lead.
 - Make sure that the bundle of thermistor lead does not interfere with any other wiring.

2.3.4. Electrical work

2.3.4.1. Caution

- (1) Follow local regulations and ordinances for technical standards related to electrical equipment, wiring, and specifications of each electric power company.
- (2) Wiring for control (hereinafter referred to as transmission line) must be situated at least 5 cm from the power source wiring so that it is not influenced by electrical noise. (Do not insert transmission line and power source wire in the same conduit.)
- (3) Be sure to provide designated grounded work to outdoor unit.
- (4) Never connect the main power source to the terminal block of a transmission line. If connected, electrical parts will be burnt out.
- (5) Use a 2-core shield cable for connecting a transmission line to TB5 of the connection kit. If transmission of different systems are wired with the same multiple-core cable, which can result in poor transmission and receipt and can cause incorrect operation.
- (6) The system will not operate if connected improperly.

TB2 : Terminal block for power supply
 TB : Terminal block for transmission line to indoor unit
 TB5 : Terminal block for transmission line to outdoor unit

- (7) Before turning the indoor unit and the connection kit on, be sure to set the switches.
- (8) To turn the power on, turn on the indoor unit, connection kit, then the outdoor unit, in that order.

- (9) For identification purposes, list the indoor unit model names in the nameplate on the control box of the connection kit.
- (10) Provide grounding for the indoor unit and the connection kit separately.
- (11) Secure the connection kit wires in place with the Cable bands (Refer to Section 2.3.4.4.) to protect against external forces.
- (12) Secure the connection kit wires in place with the Bands (Refer to Section 2.3.4.4.) to prevent fingers from coming in contact with the inside of the connection kit from the wire outlet.

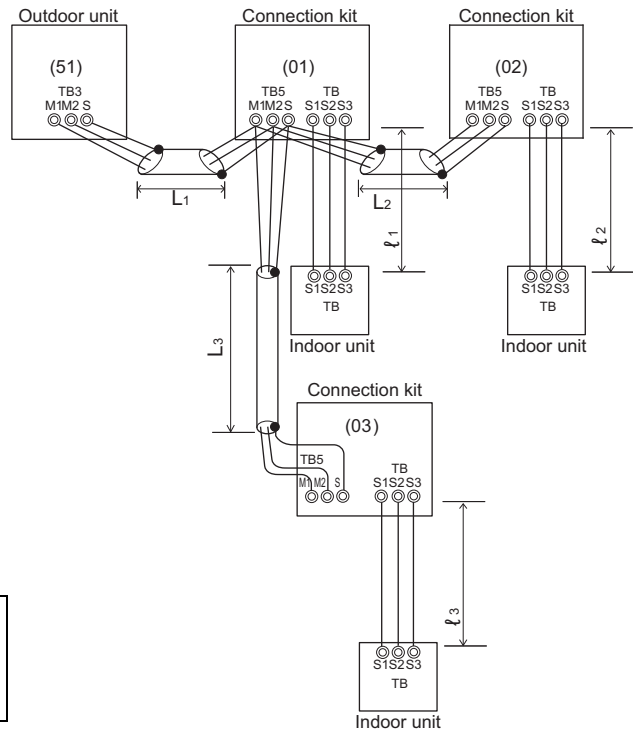

2.3.4.2. Connecting the connection kit, indoor and outdoor unit transmission cables

- Connect the outdoor unit (TB3) to the connection kit (TB5). (Non-polarized 2-wire) The "S" terminal on the connection kit (TB5) is a shielding wire connection. For connecting cable specifications, refer to the outdoor unit installation manual.
- Connect the indoor unit (TB) to the connection kit (TB). For connecting cable specifications, refer to the indoor unit installation manual.

Permissible Length

① "Indoor unit - connection kit"

Maximum transmission cable length : l_1 and l_2 , $l_3 \leq 10$ m (2-Core 1.0 mm²)

② "Outdoor unit - connection kit" + "connection kit - connection kit"

Maximum transmission cable length : $(L_1 + L_2)$ or $(L_1 + L_3)$ or $(L_2 + L_3) \leq 200$ m

2.3.4.3. Wiring of main power supply and equipment capacity

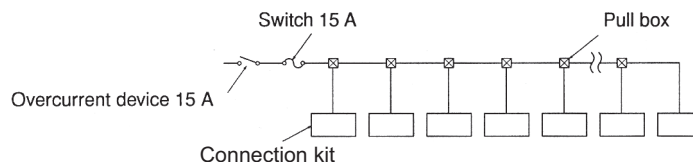

Thickness of wire for main power supply and on/off capacities

Model	Minimum wire thickness (mm ²)			Breaker for wiring (NFB)	Breaker for current leakage
	Main cable	Branch	Ground		
Connection kit	1.5	1.5	1.5	15 A	15 A

1. Use separate power supplies for the outdoor unit and connection kit.
2. Consider the ambient conditions (ambient temperature, direct sunlight, rain, etc.) when wiring and making connections.
3. The wire size is the minimum value for metal conduit wiring. The power cord size must be 1 rank thicker in consideration of voltage drops.
Make sure that the power supply voltage does not drop more than 10%.
4. Select non-fuse breaker (NFB) or earth leakage breaker (NV).
(A means for the disconnection of the supply with an isolation switch, or similar device, in all active conductors shall be incorporated in the fixed wiring.)
5. Power supply codes of appliance must not be lighter than design 60245 IEC 53 or 60227 IEC 53.
6. A switch with at least a 3 mm contact separation in each pole must be provided by the air conditioner installation.
Power cable size : more than 1.5 mm².

⚠ **Warning:**

- **Be sure to use the specified wires for connection so that no external force is imparted to the terminal connections. If the wires are not securely connected, a fire can occur.**
- **Be sure to use the appropriate type of overcurrent protection switch. Note that generated overcurrent may include some amount of direct current.**

⚠ **Caution:**

- **Some installation sites may require a ground-fault interrupter. If a ground-fault interrupter is not installed, an electric shock can occur.**
- **Use only a circuit breaker and fuse of the specified capacity. Using a fuse and copper wire with excessive capacity can cause a malfunction or a fire.**
- **The temperature set at the last operation takes priority by operating the system controller, MA/ME remote controller, or local remote controller.**

When connected to a CITY MULTI indoor unit in a system

M-NET system remote controllers cannot be used to operate the indoor unit that is connected to the connection kit.

<Restrictions>

1. The indoor unit to which the connection kit is connected cannot be in the same group to which a City Multi indoor unit belongs.
2. A group operation using M-NET between the indoor unit to which the connection kit is connected and other indoor unit cannot be performed properly if an M-NET Interface (MAC-333IF or MAC-399IF) is connected to the indoor unit using IT terminal.
3. If the connection kit is used, a group operation can be performed via the system controller or ME remote controller only. (A group operation cannot be performed via the wireless remote controller or MA remote controller.)

Examples of UNACCEPTABLE unit configurations

(1) Grouping with CITY MULTI indoor unit

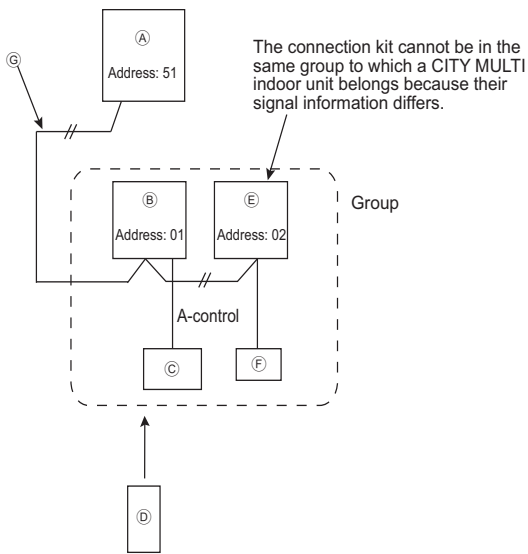

- Ⓐ Outdoor unit
- Ⓑ Connection kit
- Ⓒ Indoor unit
- Ⓓ Remote controller
- Ⓔ CITY MULTI indoor unit
- Ⓕ Remote controller (ME)
- Ⓖ M-NET transmission cable

(2) Connecting an MA & Contact Terminal Interface using IT terminal

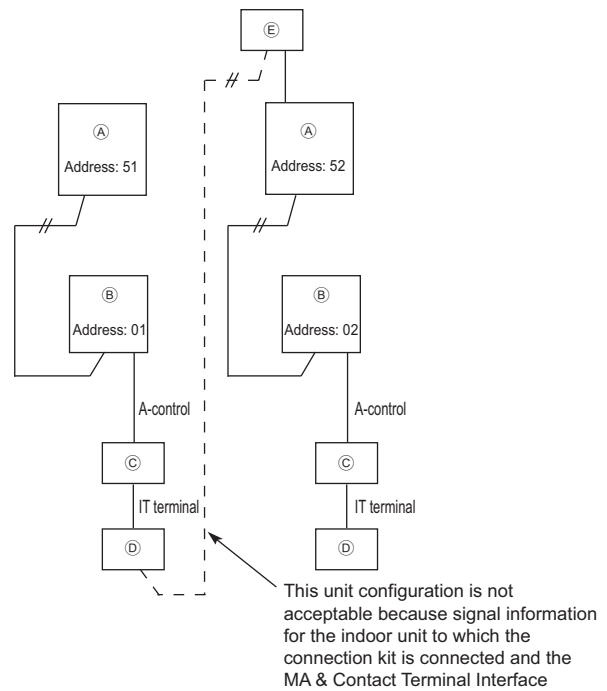

- Ⓐ Outdoor unit
- Ⓑ Connection kit
- Ⓒ Indoor unit
- Ⓓ M-NET Interface
- Ⓔ System controller

(3)-1 When using wireless remote controller

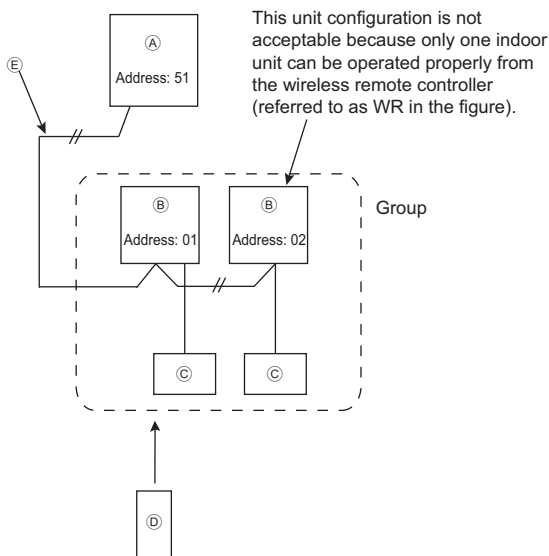

- Ⓐ Outdoor unit
- Ⓑ Connection kit
- Ⓒ Indoor unit
- Ⓓ Remote controller
- Ⓔ M-NET transmission cable

(3)-2 When using MA remote controller

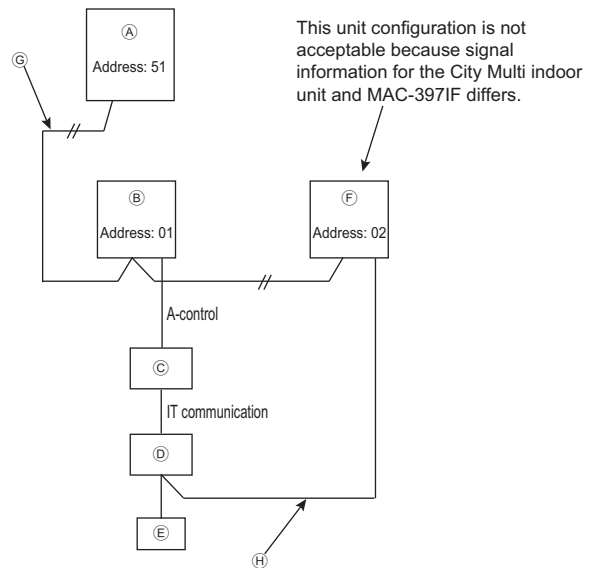

- Ⓐ Outdoor unit
- Ⓑ Connection kit
- Ⓒ Indoor unit
- Ⓓ MA & Contact Terminal Interface
- Ⓔ Remote controller (MA)
- Ⓕ CITY MULTI indoor unit
- Ⓖ M-NET transmission cable
- Ⓖ MA transmission cable

Examples of ACCEPTABLE unit configurations

(1) Connecting with CITY MULTI outdoor unit

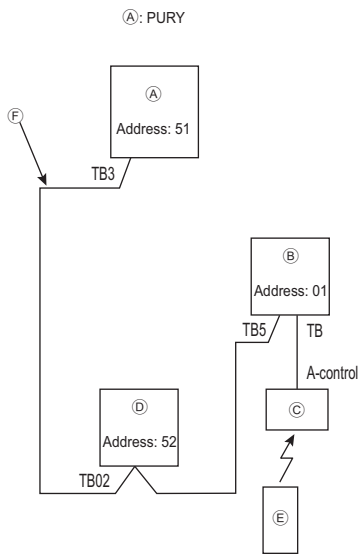

- (A) Outdoor unit
- (B) Connection kit
- (C) Indoor unit
- (D) BC controller
- (E) Remote controller
- (F) M-NET transmission cable

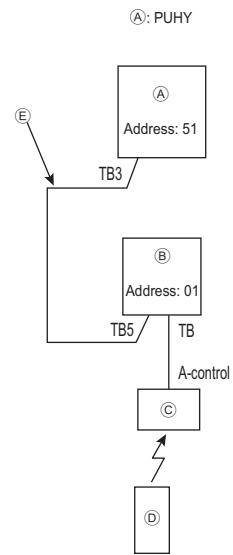

- (A) Outdoor unit
- (B) Connection kit
- (C) Indoor unit
- (D) Remote controller
- (E) M-NET transmission cable

(2) Connecting MA remote controller

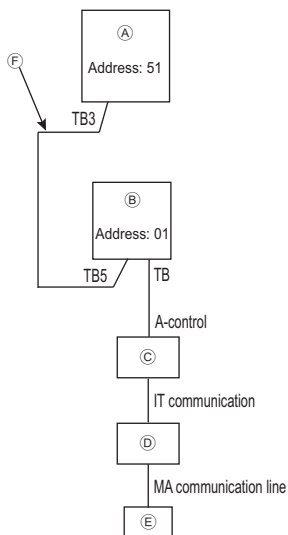

- (A) Outdoor unit
- (B) Connection kit
- (C) Indoor unit
- (D) MAC 397IF
- (E) Remote controller (MA)
- (F) M-NET transmission cable

(3) Connecting ME remote controller

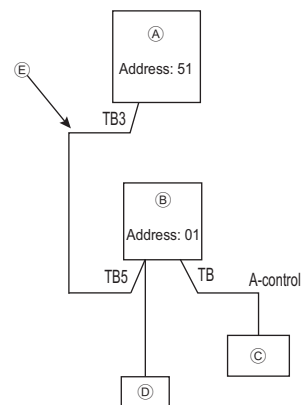

- (A) Outdoor unit
- (B) Connection kit
- (C) Indoor unit
- (D) Remote controller (ME)
- (E) M-NET transmission cable

(4) Grouping with multi-connection kit and RAC indoor units

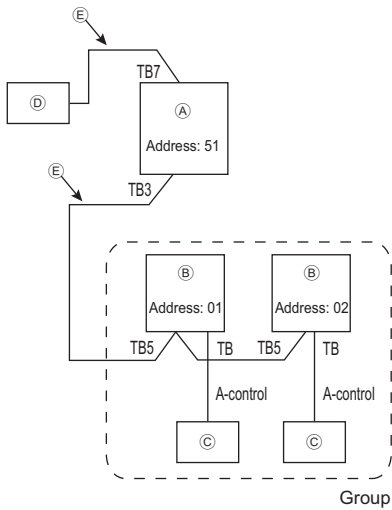

- (A) Outdoor unit
- (B) Connection kit
- (C) Indoor unit
- (D) System controller
- (E) M-NET transmission cable

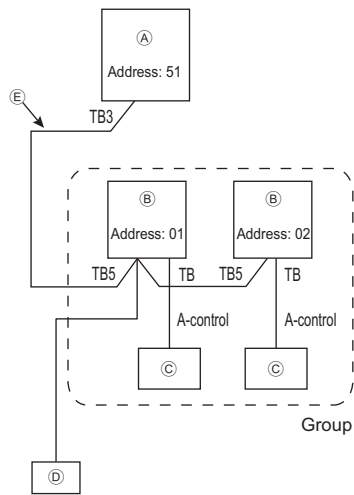

- (A) Outdoor unit
- (B) Connection kit
- (C) Indoor unit
- (D) Remote controller (ME)
- (E) M-NET transmission cable

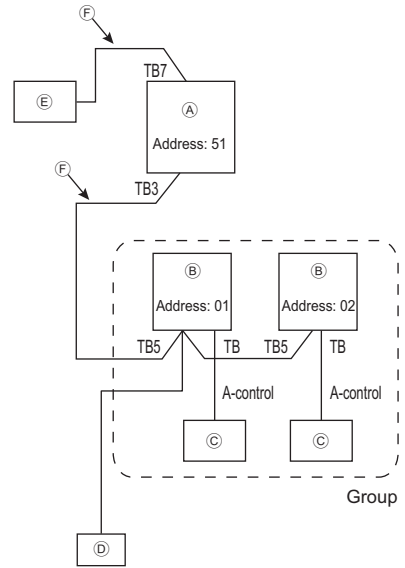

- (A) Outdoor unit
- (B) Connection kit
- (C) Indoor unit
- (D) Remote controller (ME)
- (E) System controller
- (F) M-NET transmission cable

2.3.4.4. Wiring

Check the Connection Kit accessories and parts

- ① Cable band × 2
- ② Thermistor

- (1) Remove the electrical cover.
- (2) Install the two cable bands ①.

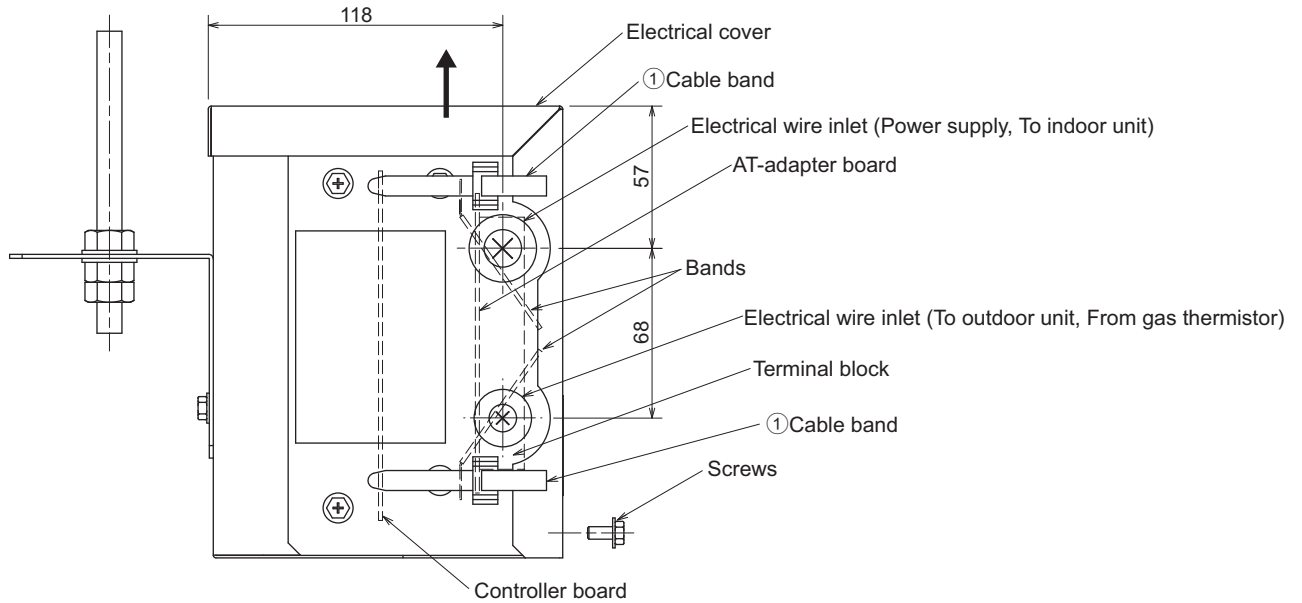

- (3) Insert the wiring and thermistor ② into the unit, and then fasten them with the bands on the inside of the unit.
- (4) Connect each wire to the terminal block securely.
- (5) Connect thermistor ② to CN44 of the controller board.
- (6) Fix the cable bands ① tightly so that the cables outside the unit will not be pulled out.

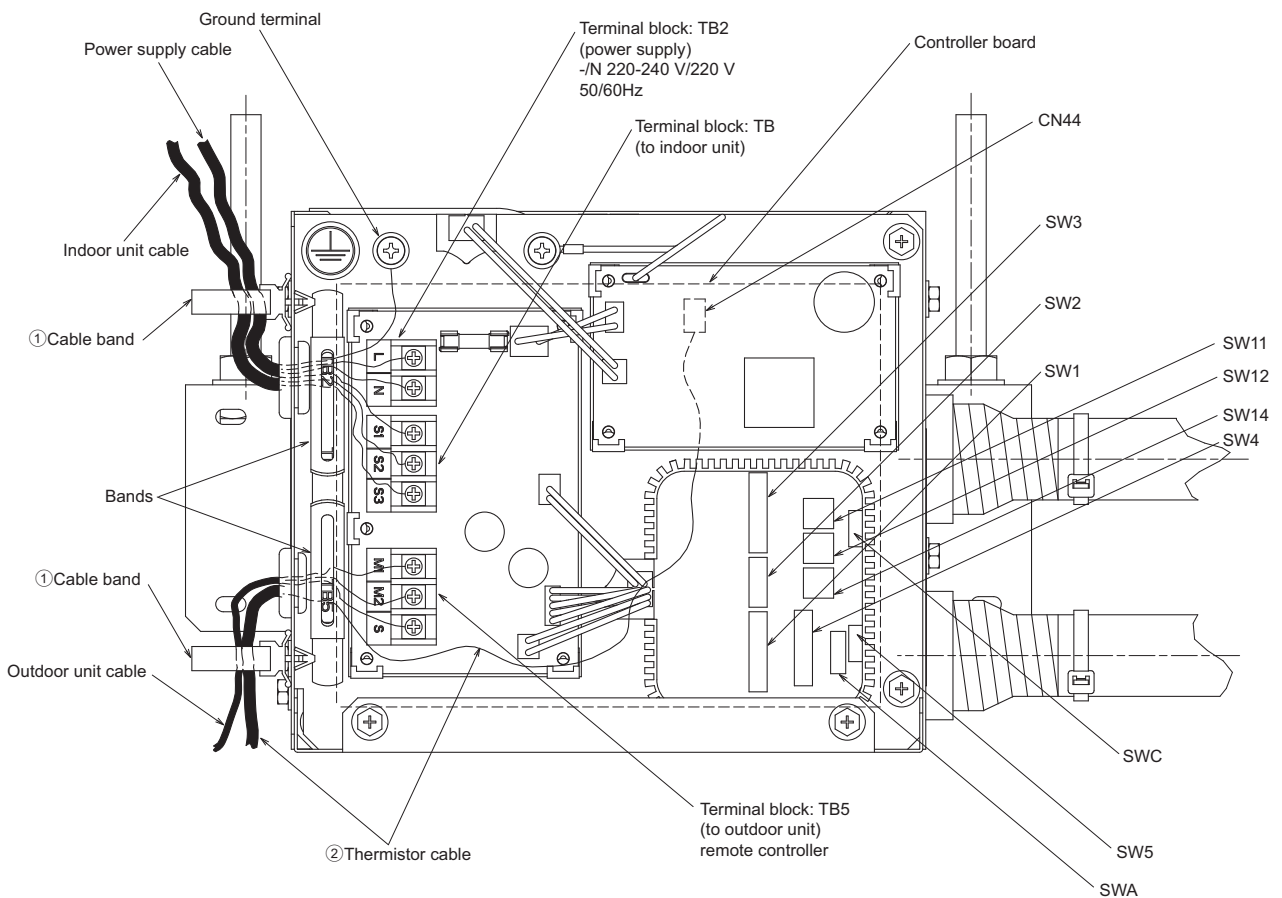

- (7) After installing the unit, install the electric cover.

2.3.5. Refrigerant piping

Indoor unit connection example

- Connect one connection kit per indoor unit.
- **Connect the connection kit the liquid pipe.**
- The thermistor-G (gas) is installed close to the connecting point of the extension piping (gas) for the indoor unit.

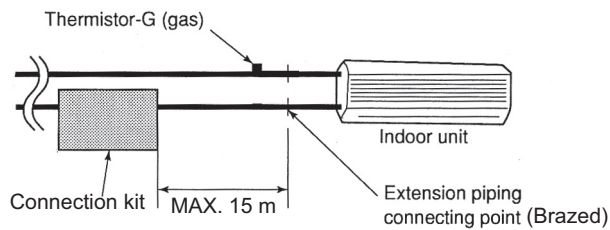

Piping connection size

Indoor unit capacity	Liquid pipe size (mm)
15-50	$\phi 6.35 \times 0.8$

* Connection kit $\phi 6.35 \times 0.8$

Additional refrigerant quantity

- If necessary, add additional refrigerant to the unit by following the calculation method given in the outdoor unit manual.
- When calculating the refrigerant quantity, be sure to include the connection kit-to-indoor unit liquid pipe length.
- The amount of refrigerant required by the indoor units must be charged to the system. Refer to the manual that came with the outdoor unit for details.
- Some indoor units require additional refrigerant charge. Refer to the “LEV kit connectable unit model list” (WT08359) for details. Obtain the “LEV kit connectable unit model list” (WT08359) using either of the following methods:
 - Download from Next2.
 - Consult your dealer.

2.3.6. Error code

The table below summarizes the error codes for the indoor and outdoor units that are connected to the connection kit. Refer to the relevant Service Handbook for other error codes.

Error code	Indoor unit error code (reference)	Error type
0404	Fb, FC	Indoor unit EEPROM abnormality
4124	PE	Electric system not operate due to damper abnormality
6840	E6, E8	A control communication reception error
6841	E9	A control communication synchronism not recover
6842	E7, E9	A control communication transmission/reception hardware trouble
6843	E6, E8	A control communication start bit detection error

2.4. Dip switch setting

(1) SW2

Set the dip switches in the connection kit as follows to configure the capacity settings for the connected indoor unit.

Model	P15-P20	P22	P25	P32, P35	P40, P42	P50	P63
Capacity (model) code	3	4	5	6	8	9	13
SW2 setting							
Model	P71	P80	P100	P125	P140	P200	P250
Capacity (model) code	14	16	20	25	28	40	50
SW2 setting							

Note. The setting timing for SW2 is before power is turned on.

(2) SW4

Set the dip switches in the connection kit as follows.

Some indoor units require dip SW4 setting changes. Refer to the "LEV kit connectable unit model list" (WT08359) for details.

Obtain the "LEV kit connectable unit model list" (WT08359) using either of the following methods:

- Download from Next2.
- Consult your dealer.

SW4 setting



Set the dip switches as follows when the unit is used in a high temperature and humidity environment. However, the fan speed may vary depending on the operating environment.

SW4 setting

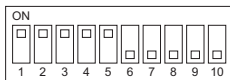

The figure at left shows that the switches 1 through 5 are set to ON and 6 through 10 are set to OFF.

(3) Address switch

Actual indoor unit address setting varies in different systems. Refer to the installation manual for the outdoor unit for details on how to make the address setting.

Each address is set with a combination of the settings for the 10's digit and 1's digit.

(Example)

When setting the address to "3", set the 1's digit to 3, and the 10's digit to 0.

When setting the address to "25", set the 1's digit to 5, and the 10's digit to 2.

(4) BRANCH No. setting (Only PURY)

Setting method

- Assign the smallest address to the main unit in the group.
- In a system with a sub BC controller, make the settings for the indoor units in the following order.

(i) Indoor unit to be connected to the main BC controller

(ii) Indoor unit to be connected to sub BC controller 1

(iii) Indoor unit to be connected to sub BC controller 2

Make the settings for the indoor units in the way that the formula "(i) < (ii) < (iii)" is true.

Note

- In case of connecting with BC controller, BRANCH No. setting is required.

(5) Other

When the unit is used in a high-temperature and humidity atmosphere, change the dip switch settings of the outdoor unit as follows.

Model	Dip switch setting	
PUHY/PURY -*H* series -*J* series	SW4	SW4-1: ON
PUHY/PURY -*K* series or later	SW4 1-10 (0: OFF, 1: ON)	1000000111 (897)

3. Specifications

SPECIFICATIONS OF OPTIONAL PARTS			
MODEL	PAC-LV11M-J		
Power source	Single/220-240 V/50/60 Hz		
Connectable number of indoor units	1		
External finish	Hot-dip zinc-coated steel sheet (No external finish)		
External dimension H×W×D	mm	183 × 355 × 142	
Net weight	kg	3.5	
Refrigerant piping diameter	Liquid pipe	mm	6.35 Brazed
	Gas pipe	mm	-
Wiring	To Outdoor unit		2-core shield cable

•The A-weighted sound pressure level is below 70 dB.

4. Outlines and dimensions

- Note 1. Please attach a gas thermistor to the gas pipe of a spot.
 2. When this is shipped from the factory, the installation plate is not attached to the main body.
 3. When you install the unit on a wall, please attach the installation plate referring to the left figure. (M5×10)
 4. When you use the suspension bolt, please attach the installation plate inside out.
 5. Suspension bolt (ø10), washer (M10), and nut (M10) prepare in the field.

<Accessories>

- Installation plate.....1pc.
- Gas thermistor.....1pc.
- Thermistor holder (ø9.52).....1pc.
- Thermistor holder (ø12.7).....1pc.
- Screw bolt (M5×10).....2pc.
- Pipe cover.....2pc.
- Cable band.....2pc.

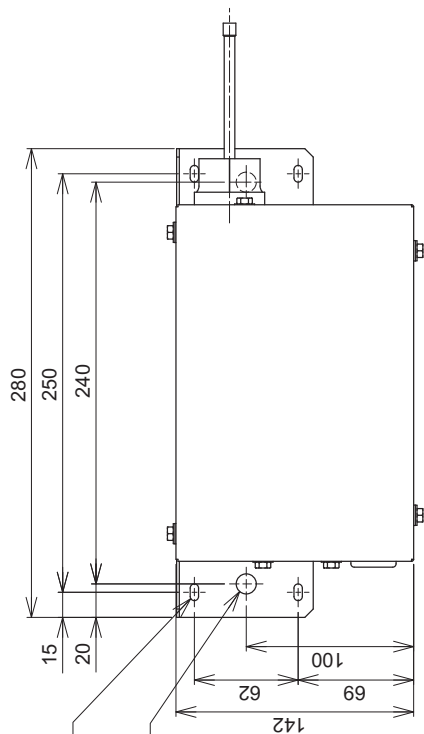

4-10×5 oblong holes
(For plane surface installation)

2-ø12 holes
(For suspension bolt)

<POWER SUPPLY>
 Wiring to terminal block: TB2
 1-phase 220-240V 50, 60Hz
 < To indoor unit >
 Wiring to terminal block: TB

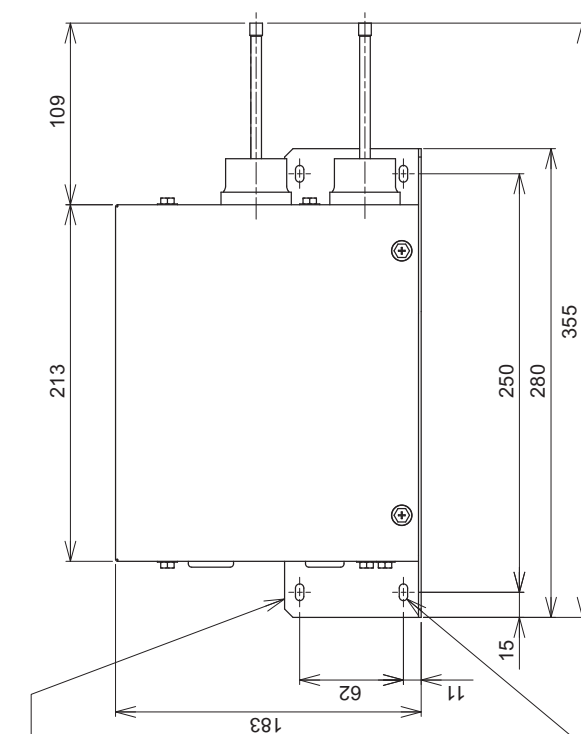

Installation plate

Screw bolt (M5×10)

Note 3

< To outdoor unit >
 Wiring to terminal block: TB5
 < To gas pipe >
 Wiring from gas thermistor

4-10×5 oblong holes
(For wall surface installation)

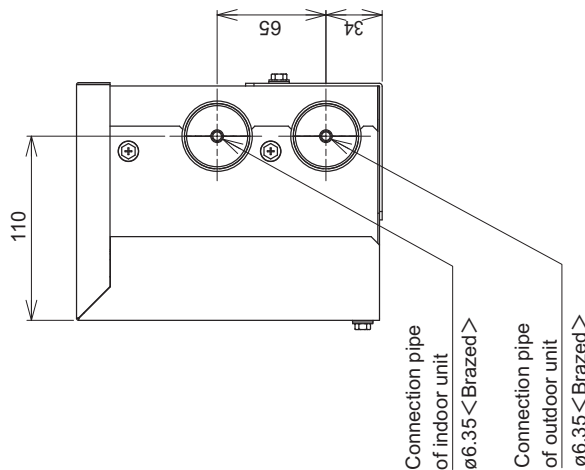

Connection pipe
of indoor unit
ø6.35 < Brazed >

Connection pipe
of outdoor unit
ø6.35 < Brazed >

5. Wiring diagram

CITY MULTI CONNECTION KIT

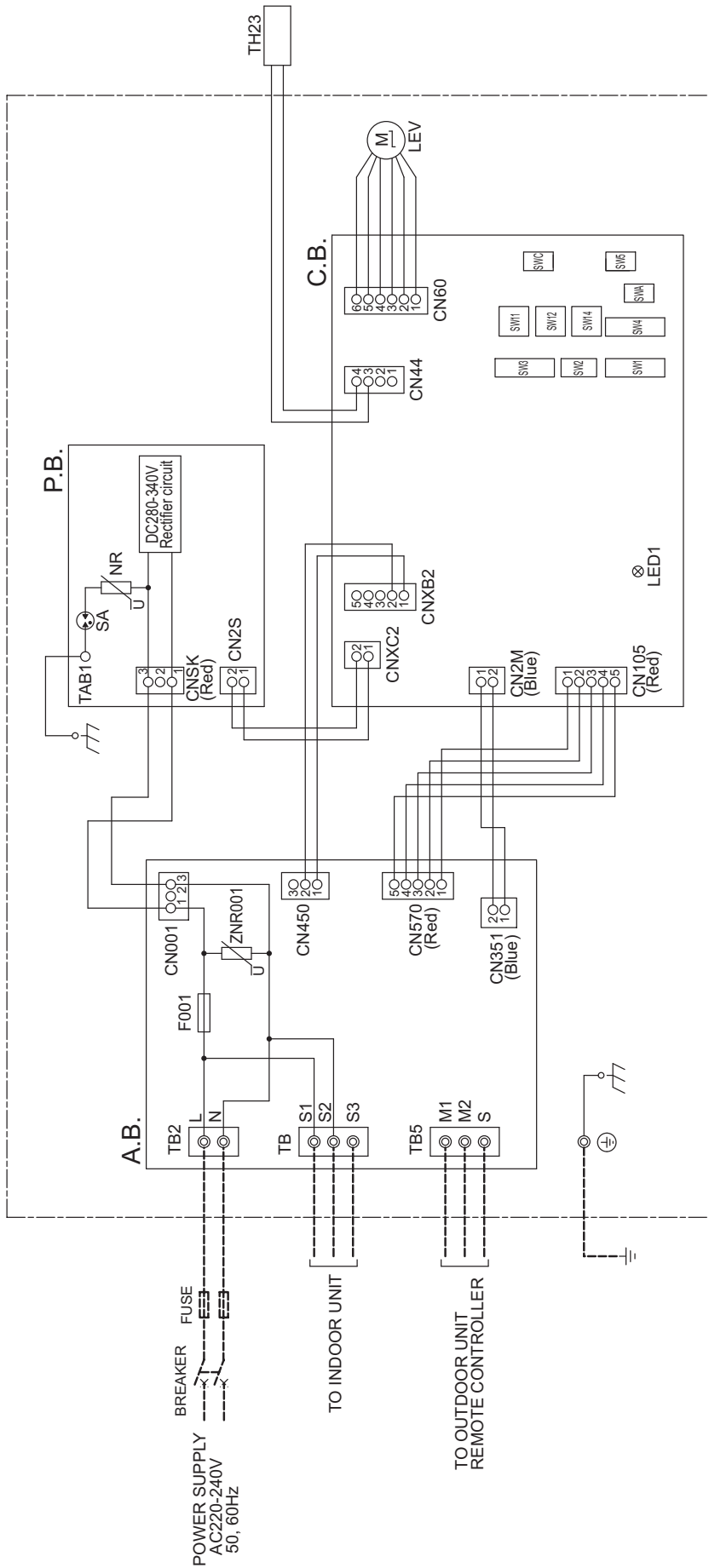

SYMBOL EXPLANATION

SYMBOL	NAME	SYMBOL	NAME
C.B.	Controller board	SW1(C.B.)	Switch (for mode selection)
P.B.	Power supply board	SW2(C.B.)	Switch (for capacity code)
A.B.	AT-adapter board	SW3(C.B.)	Switch (for mode selection)
TB2	Power source terminal block	SW4(C.B.)	Switch (for mode selection)
TB	Transmission terminal block	SW5(C.B.)	Switch (for mode selection)
TB5	Transmission terminal block	SW11(C.B.)	Switch (1s digit address set)
F001	Fuse AC250V 6.3A	SW12(C.B.)	Switch (10ths digit address set)
ZNR001	Varistor	SW14(C.B.)	Switch (BRANCH No.)
NR	Varistor	SWA(C.B.)	Switch (for static pressure selection)
SA	Surge Absorber	SWC(C.B.)	Switch (for static pressure selection)
TH23	Thermistor (piping temp.detection/gas pipe)	LEV	Linear expansion valve
LED1	LED (Power supply)		

NOTE: Symbols used in wiring diagram above are,

⊙: Terminal

----- (Heavy dotted line): Field wiring

6. Refrigerant system diagram

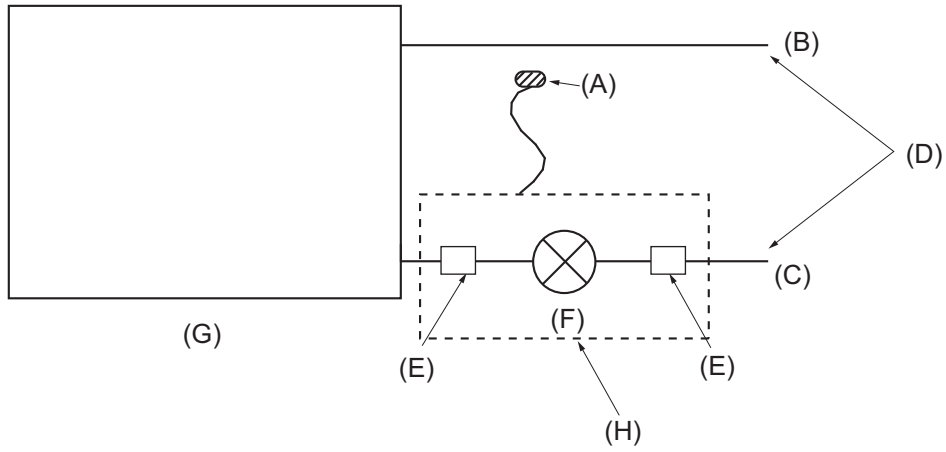

- (A) Gas pipe thermistor TH23
- (B) Gas pipe
- (C) Liquid pipe
- (D) Brazed connections
- (E) Strainer (#100 mesh)
- (F) Linear expansion valve
- (G) Indoor unit
- (H) Connection kit

7. Troubleshooting

7.1. Test run

⚠ Caution:

Before operating the unit, check that the wiring, piping, and thermistor are installed and that the switches have been set. Refer to the "Test run" section of the indoor units and outdoor unit installation manuals.

After installation of an indoor unit, connection kit, and outdoor unit, begin a test run to check water leaks in the connection kit.

Be sure to perform a test run in cooling mode for each indoor unit installed. Make sure that each indoor unit operates properly following the installation manual supplied with the unit.

If a test run is performed on all indoor units at once, improper connection of the refrigerant pipes and the indoor and outdoor unit connecting wires cannot be detected.

⚠ Caution:

- **Always use the remote controller to operate the indoor unit.**
- **When using a connection kit, operation from the outdoor unit is not possible.**
- **The following symptoms are not malfunctions.**

Symptom	Cause	Indoor unit LED display *
Indoor unit does not operate even if set to cooling (heating) operation	The cooling (heating) operation cannot be operated when the cooling (heating) operation of another indoor unit is operating.	Stand by (For Multi System)
Indoor unit fan stops during heating operation	The fan stops during defrosting operation.	-
	Fan stops when the refrigerant collecting mode ** is activated. When this occurs, the vanes close.	Stand by (For Multi System)

* See the operation manual of indoor units for details.

** This mode is activated for approximately 1 minute to help avoid an insufficient supply of refrigerant during heating operation when refrigerant is stored in an indoor unit that has been turned off or thermo-off.

- A hissing noise can be heard immediately after the air conditioner is started or stopped. This is the sound of the refrigerant flowing inside a connection kit. The problem is insignificant.

7.2. Check methods

1. Component and check points

(1) Thermistor

•Gas pipe thermistor (TH23)

Disconnect the connector and measure the resistance between terminals with a tester.
(Ambient temperature 10°C - 30°C)

Normal	Abnormal
4.3kΩ - 9.6kΩ	Open or short

(Refer to the thermistor characteristic graph below.)

1) Thermistor characteristic graph

Low-temperature thermistor

•Gas pipe thermistor (TH23)

•Thermistor $R_0 = 15 \text{ k}\Omega \pm 3\%$

•Multiplier of B = $3480 \text{ k}\Omega \pm 2\%$

$$R_t = 15 \exp \left\{ 3480 \left(\frac{1}{273+t} - \frac{1}{273} \right) \right\}$$

0°C	15kΩ
10°C	9.6kΩ
20°C	6.3kΩ
25°C	5.2kΩ
30°C	4.3kΩ
40°C	3.0kΩ

(A) Temperature (°C)

(B) Resistance (kΩ)

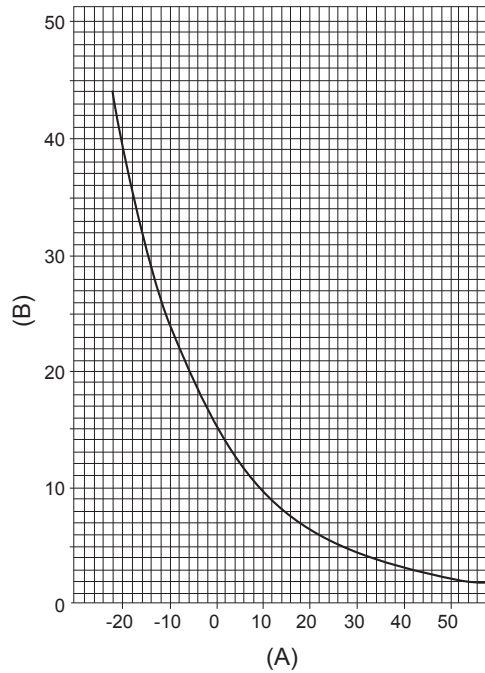

(2) Linear expansion valve

Disconnect the connector, and measure the resistance between terminals with a tester.
Refer to the next page for details.

	Normal				Abnormal
	1-5 White-Red	2-6 Yellow-Brown	3-5 Orange-Red	4-6 Blue-Brown	Open or short
	200 kΩ ± 10%				

(A) Brown

(D) Orange

(B) Red

(E) Yellow

(C) Blue

(F) White

1) Summary of linear expansion valve (LEV) operation

- The LEV is operated by a stepping motor, which operates by receiving a pulse signal from the controller board.
- The LEV position changes in response to the pulse signal.

Controller board and LEV connection

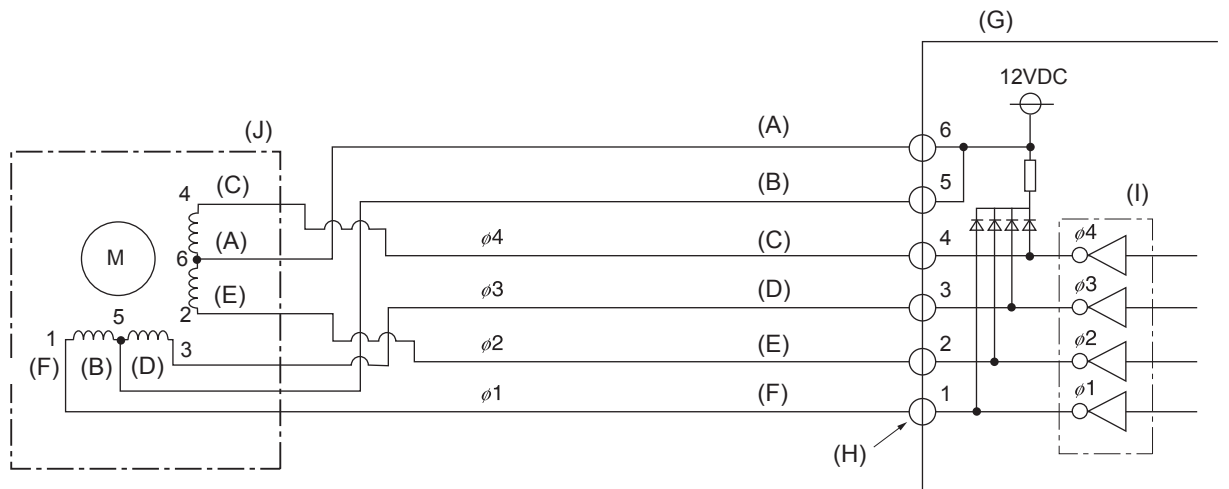

- (A) Brown
- (B) Red
- (C) Blue
- (D) Orange
- (E) Yellow
- (F) White
- (G) Control board
- (H) Connection (CN60)
- (I) Drive circuit
- (J) Linear expansion valve

Pulse signal output and valve operation

Phase number	Output pulse			
	1	2	3	4
ø1	ON	OFF	OFF	ON
ø2	ON	ON	OFF	OFF
ø3	OFF	ON	ON	OFF
ø4	OFF	OFF	ON	ON

The output pulse changes in the following order:

When the valve closes 1 -> 2 -> 3 -> 4 -> 1

When the valve opens 4 -> 3 -> 2 -> 1 -> 4

- When the valve position remains the same, all output signals will be OFF.
- If any output signal is missing or if the signal remains ON, the motor vibrates and makes clicking noise.

2) LEV operation

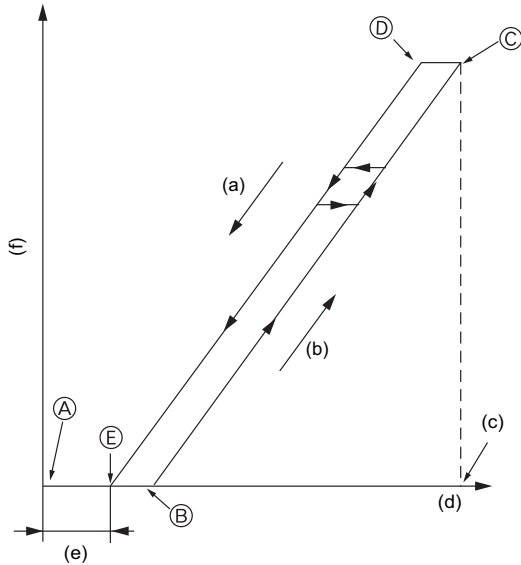

- (a) Close
- (b) Open
- (c) Fully open valve (2000 pulses)
- (d) No. of pulses
- (e) Extra tightening (80 - 100 pulse)
- (f) Valve opening degree

- When the power is turned on, a pulse signal of 2200 pulses is output (valve closure signal), to bring the valve to position (A).
- When the valve is operating normally, it is free of vibration noise. If the valve locks or when it goes from point (E) to (A) in the figure, it makes louder noise than would be heard when there is an open phase.
- Check for abnormal sound/vibration by placing the metal tip of a screwdriver against the valve and the handle side against your ear.

3) Troubleshooting

Symptom	Checking Criteria	Remedy
Circuit failure on the microcomputer	<p>Disconnect the connectors on the control board, and connect LEDs to test the circuit as shown below.</p> <p>Pulse signals are output for 10 seconds when the main power is turned on. If there are LEDs that do not light up at all or remain lit after the pulses are turned off, there is a problem with the driving circuit.</p>	Replace the controller board if driving circuit failure is detected.
Locked LEV	The motor will idle and make small clicking noise if it is run while the LEV is locked. If this clicking noise is heard both when the valve is fully closed and while it is being opened, it indicates a problem.	Replace the LEV.
Disconnected or shorted LEV motor coils	Measure the resistance between the coils with a tester (red-white, red-orange, brown-yellow, brown-blue). The normal range of resistance is $150 \Omega \pm 10\%$	Replace the LEV.

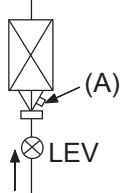
Symptom	Checking Criteria	Remedy
Valve closure failure (leaky valve)	<p>To check the LEV on the connection kit, check the indoor unit liquid pipe temperature that appears on the operation monitor on the outdoor unit's multi control board while operating the indoor unit in question in the FAN mode and the other indoor units in the cooling mode.</p> <p>(A) Thermistor (RT12, RT13)</p> 	Replace the LEV if the amount of leakage is great.
	<p>Normally, the LEV is fully closed while the unit is in the FAN mode. If the valve is leaky, liquid pipe thermistor reading will be lower than normal. If it is significantly lower than the ambient temperature, valve closure failure is suspected. If the amount of leakage is insignificant, replacement of LEV is unnecessary unless it is causing a problem.</p>	
Misconnections of connectors or contact failure	<p>Perform a visual check for disconnected connectors.</p> <p>Perform a visual check of lead wire color.</p>	Disconnect the connectors on the control board and perform a continuity test.

7.3. Dip switch setting (Factory setting)

1. Function setting
- (1) SW1

Switch position	Function	Switch setting	
		ON	OFF
1	-	-	-
2	-	-	-
3	-	-	-
4	-	-	-
5	-	-	-
6	-	-	-
7	-	-	-
8	-	-	-
9	Auto restart after power failure	Enabled	Disabled
10	Power start/stop	Enabled	Disabled

Factory setting



- (2) SW3

Factory setting

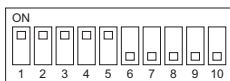
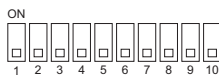

The figure at left shows that the switches 1 through 5 are set to ON and 6 through 10 are set to OFF.

2. Capacity code setting

(1) SW2

Dipswitch settings must be made while the unit is stopped.
 Factory setting = Every switch is set to OFF.
 The switches are set to correspond to the indoor unit capacity.

Model	P15-P20	P22	P25	P32, P35	P40, P42	P50	P63
Capacity (model) code	3	4	5	6	8	9	13
SW2 setting							

Model	P71	P80	P100	P125	P140	P200	P250
Capacity (model) code	14	16	20	25	28	40	50
SW2 setting							

Note. The setting timing for SW2 is before power is turned on.

3. Model setting

(1) SW4

Dipswitch settings must be made while the unit is stopped.

Factory setting

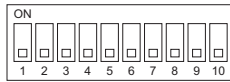

Note:

Changes made to the dipswitches SW1, SW2, and SW3 will become effective when the unit comes to a stop (remote controller off). There is no need to power cycle the unit.



The figure at left shows that the switches 1 through 5 are set to ON and 6 through 10 are set to OFF.

4. Power voltage setting

(1) SW5

Dipswitch settings must be operated with the main power turned OFF.

Factory setting



Set SW5 to 240V side when the power supply is 240 volts.
 When the power supply is 220 and 230 volts, set SW5 to 220V side.

5. External static pressure (The SWA and SWC switches on the connection kit will not be used.)

(1) SWA, SWC

Factory setting

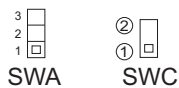

6. 1s and 10ths digits

(1) SW11, SW12 (Rotary switch)

The connection kit requires address setting.
 Address settings must be made while the unit is stopped.

Factory setting

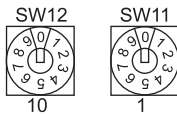

7. BRANCH No. setting

(1) SW14 (Rotary switch)

This switch is used when the unit connected to an R2 series of outdoor unit.

Factory setting



Note:

Changes to the dipswitches SW11, SW12, SW14, and SW15 must be made while the unit is stopped and the remote controller is OFF.



CITY MULTI CONNECTION KIT

MODEL

REFRIGERANT	R410A
ALLOWABLE PRESSURE (Ps)	4.15 MPa
WEIGHT	kg
IP CODE	IP20
YEAR OF MANUFACTURE	

SERIAL No.

VOLTAGE	V	220	230	240
FREQUENCY	Hz	50/60	50/60	50/60
INPUT	W			
CURRENT	A			

MANUFACTURER:
 MITSUBISHI ELECTRIC CORPORATION
 AIR-CONDITIONING & REFRIGERATION SYSTEMS WORKS
 5-66, TEBIRA, 6-CHOME, WAKAYAMA CITY, JAPAN
 MADE IN JAPAN

This product is designed and intended for use in the residential,
commercial and light-industrial environment.

The product at hand is
based on the following
EU regulations:

- Low Voltage Directive 2014/35/EU
- Electromagnetic Compatibility Directive
2014/30/EU

Please be sure to put the contact address/telephone number on
this manual before handing it to the customer.

MITSUBISHI ELECTRIC CORPORATION

HEAD OFFICE: TOKYO BLDG., 2-7-3, MARUNOUCHI, CHIYODA-KU, TOKYO 100-8310, JAPAN